



可靠耐久 新标杆



CG960K

轮式装载机
WHEEL LOADER

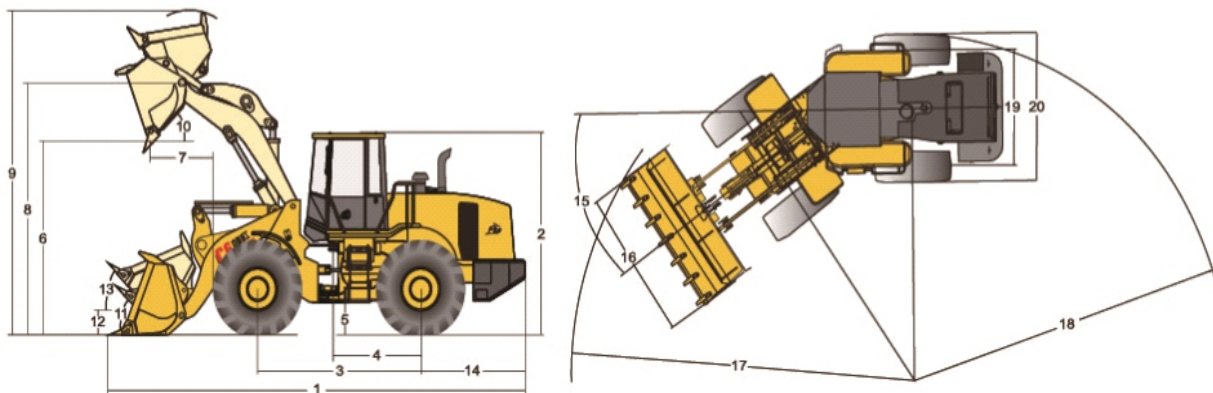

整机外形尺寸 (长×宽×高) 8500×3130×3550mm

Overall dimension

| | | | | | |
|----|---|------|----|---|------|
| 1 | Overall length(mm) | 8500 | 11 | Rollback(at ground position)(°) | 44.6 |
| 2 | Overall height(mm) | 3550 | 12 | Height of articulation of arm at carry position(mm) | 550 |
| 3 | Wheel base(mm) | 3380 | 13 | Max rollback (at carry position) (°) | 50 |
| 4 | Articulation to rear axle(mm) | 1690 | 14 | Center of rear axle to counter weight(mm) | 2000 |
| 5 | Minimum ground clearance(mm) | 465 | 15 | Turning radius angle(°) | 36 |
| 6 | Dump height(45° dump angle)(mm) | 3290 | 16 | Overall width(bucket width)(mm) | 3130 |
| 7 | Dump clearance(at maximum dump height) (mm) | 1201 | 17 | Min.turning radius(Outer side of bucket)(mm) | 7374 |
| 8 | Height to hinge pin(full raised) (mm) | 4363 | 18 | Min.turning radius(Outer side of rear wheel)(mm) | 6627 |
| 9 | Maximum working height(full raised)(mm) | 5842 | 19 | Wheel tread(mm) | 2200 |
| 10 | Dump angle(At maximum lifting position)(°) | 45 | 20 | Max. Machine width(mm) | 2768 |

Main Technical Specifications

| Item | Parameter |
|-------------------------------------|--|
| Operation parameter | |
| Operating Mass(kg) | 19700 |
| Bucket Capacity(m ³) | 3.5-5 |
| Rated load weight(kg) | 6000 |
| Maximum traction force(kN) | 176 |
| Maximum breakout force(kN) | 168 |
| Maximum grade ability(°) | 28 |
| Max travel speed(km/h) | 39 |
| Operation parameter | |
| Model | WEICHAI WP10G240E341 Emission standard:Level III(EURO III) |
| Type | Electronically controlled,inline, four-stroke,supercharged engine |
| Cylinder-Bore x stroke(mm) | 6 - Φ126x130 |
| Maximum peak torque(kW) | 178 |
| Rated rpm(r/min) | 2200 |
| Torque converter and gearbox | |
| Torque converter type | 4-element,Dual turbine |
| Gearbox | Chenggong power control shift gearbox |
| Number of gears | 2 Forward 1 reverse |
| Drive axle | |
| Main transmission type | 1st level spiral bevel gear deceleration |
| Wheel side braking type | Planetary gear deceleration |
| Drive axle braking type | Dry axle |

| Item | Parameter |
|---|---|
| Tire | |
| Specification | 23.5-25-20PR |
| Front tire pressure(MPa) | 0.35 |
| Rear tire pressure(MPa) | 0.25 |
| Pattern type | L3 |
| Hydraulic System | |
| Working system pressure(Mpa) | 19 |
| Arm lifting time(s) | 5.8 |
| Complete loading and unloading time(≤s) | 9.8 |
| Steering system | |
| Type | Full hydraulic flow amplification hinge joint steering |
| System pressure(Mpa) | 17.2 |
| Braking system | |
| Travel braking | Air-Over-Oil caliper disc brake on all four wheels |
| Parking brake | Caliper type brake |
| Service refill capacities | |
| Fuel tank(L) | 310 |
| Hydraulic system(L) | 128 |
| Engine(L) | 24 |
| Torque converter and transmission(L) | 34 |
| Axle(each front and rear) (L) | 26 |
| Cooling system(radiator) | 42 |

成工重工(遂宁)机械有限公司

CHINA CHENGGONG HEAVY (SUINING) INDUSTRY CO., LTD.

Address: No. 999, Yinhe South Road, economic and Technological Development Zone, Suining, Sichuan

Tel: 4006 305090

Postal Code: 629000

website: www.cgzgc.com

